

Appliqué Book Cover

*A gift to you from Linda Goodejohn and provided by
The Elly Sienkiewicz Appliqué Academy®llc 2011*



*Note: The pattern used in this photo can be found
in "Baltimore Elegance" by Elly Sienkiewicz.*

*Create a keepsake fabric cover for your
favorite book. Add your personal appliqué to
enhance its beauty and enjoy the durability
that a cover provides. One of these special
book covers would make a cherished gift.*

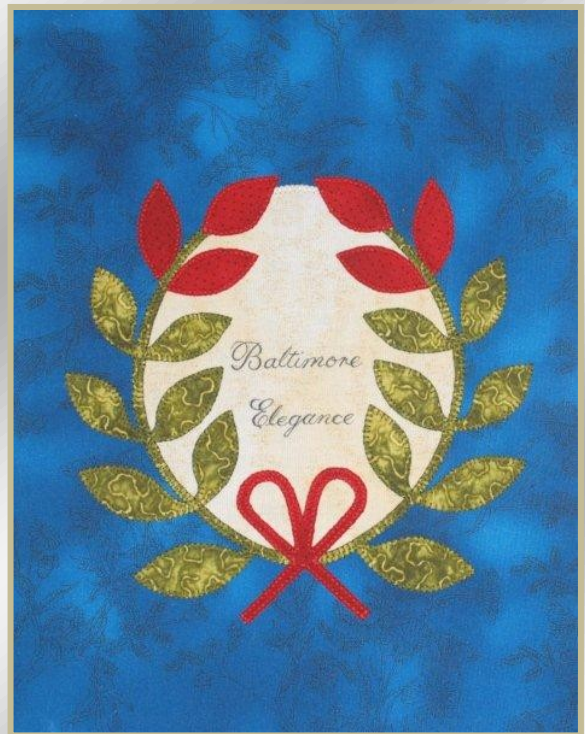

Materials and Supplies

- 3/8 yard fabric for cover
- Assorted fabrics for appliqués and spine label
- ½ yard light weight fusible interfacing (22 inch wide)
- Lite Steam-A-Seam 2 or other fusible web for appliqués
- Thread to match fabrics
- Permanent pen such as Pigma Pen .01
- Light box (optional)

Pattern Design by Linda Goodejohn

Email: lgoodejohn@comcast.net

Illustrated by Jill Bouratoglou (my talented daughter)

Additional Notes for Beloved Baltimore Album Quilt's Book Cover

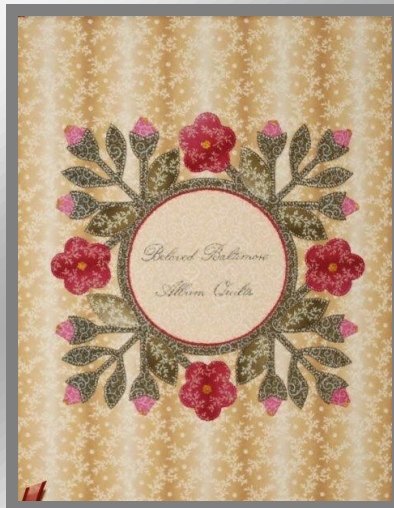

Front

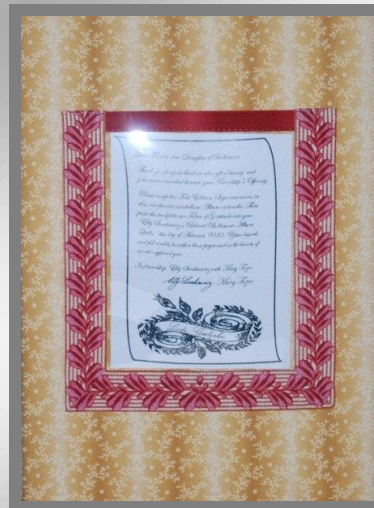

Back

- Interface the inside front cover for extra support if a pocket is to be applied. $\frac{3}{4}$ yard total interfacing would be needed.
- For a see thru pocket use heat resistant template plastic. This is especially useful for viewing a bookplate. Cut the plastic 5 x 6 inches. To finish the top edge, cut a strip of fabric $1\frac{1}{2}$ x 5 inches. Fold under $\frac{1}{4}$ inch and press on each long side. Fold in half lengthwise and top stitch with template plastic in between the fold. Using a stripe fabric, cut a strip $1\frac{1}{2}$ x $20\frac{1}{2}$ inches. Fold the long edges in $\frac{1}{4}$ inch and press. Position the stripe about $\frac{1}{2}$ inches over the edges of the template plastic on the sides and bottom creating miters at the bottom corners. Turn under the top edges and top stitch around the stripe fabric on both sides and top, catching the plastic with the inside stitching. Remember that the pocket must be sewn before the book cover is assembled.
- If desired, a fabric pocket or two can be added of any size. They could be trimmed with fabric bindings or decorative trims and threads. The edges could be simply turned under and top stitched. Make sure that the whole book cover is interfaced if you decide to put a pocket on the back inside cover.
- The cover pattern used in the sample is the Rake Ruched Rose of Sharon on page 94 of *Beloved Baltimore Album Quilts*. The design was applied with fusible web layering the center fabric first with the folded buds, stems, flowers, and leaves following. Each piece was machine sewn around the edges with a blanket stitch using coordinating colored threads. French knots were used for the flower centers and buds. A stem stitch decorated the inside ring.
- A book mark was added to the top of the spine. Use a ribbon of your choice that is $\frac{1}{4}$ inch wide and 15 inches long. Before doing the final assembly, slip the ribbon into the seam allowance at the top of spine making sure that it is positioned straight and catch in the stitching.
- The inking on the spine and cover was done by first printing out the words and then tracing the fabric using a light box. The fonts used were *Times New Roman 21* on the spine and *Kunstler Script 38* on the cover.

Book Cover Directions

The measurements in parenthesis are for a 8-1/2" x 11" x 1/2" book.

1. Measure inside the front cover from 1/2" of spine around the outside front cover of book to the inside of the back of the book to 1/2" of spine. Make sure to close book completely to get an accurate measurement. (Total width for our book will be 33 1/2".)

2. Determine measurements of fabric by measuring height and width of book and adding 1" seam allowance for height (12" total), and 1/2" seam allowance for width (34" total).

3. After determining measurements of book to be covered, cut out the fabric for the book cover and save the remaining piece for the facing (12" x approximately 7"). Selvages should be removed before measuring and cutting.

4. Cut out the fusible interfacing the exact size of the outside of the book. That would be the front and back cover plus the spine. (17 1/2"x11").

5. Center the interfacing on the back side of the fabric and fuse according to manufacturers instructions.

6. Overcast each short end of fabric. Turn each end under 1/4" to wrong side and stitch down.

7. Measure width of spine. From contrasting fabric cut a piece of fabric the width of spine plus 1/2" by the length of the book cover plus 1/2" (1"x12"). Apply fusible interfacing to the center of spine label (11" x 1/2"). Using a permanent pen, write the author and title of book on the strip of fabric. Use a light box if necessary. Heat set all inking with an iron.

8. Fold under 1/4" along each long side. Position the strip on vertical center of book cover. Stitch with matching thread close to each long edge.

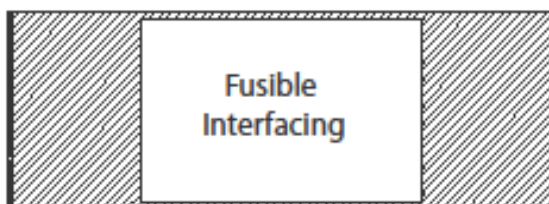
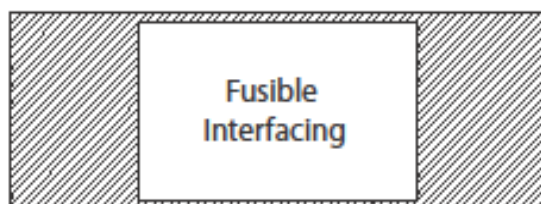
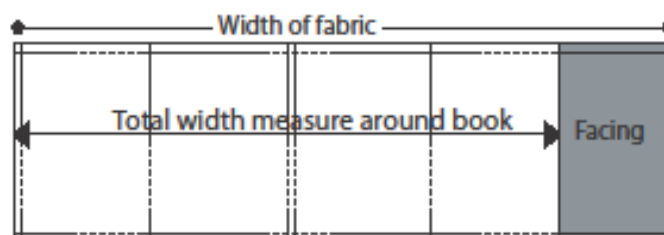
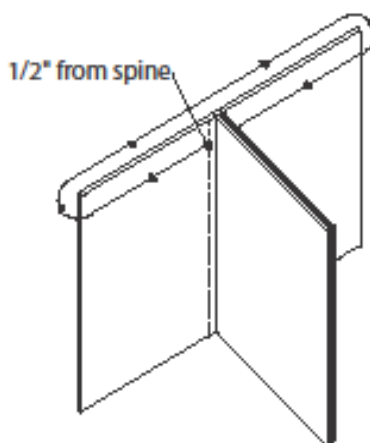

9. Measure and crease or mark fabric to determine the location of the front cover of book for embellishment.

10. Now is the time to add the appliqué. Trace design in reverse onto fusible web and iron to wrong side of fabric according to manufacturer's directions. Cut out design and position on desired area and fuse down. After it is secure, stitch edges with thread of choice using a blanket stitch or other decorative stitch.

To complete cover:

11. Fold front flap back on fold line and pin right sides together. Fold back flap on fold line with right sides together the same as front. Position facing (unhemmed) over book cover, right side down, centered over flaps. Pin or baste together.

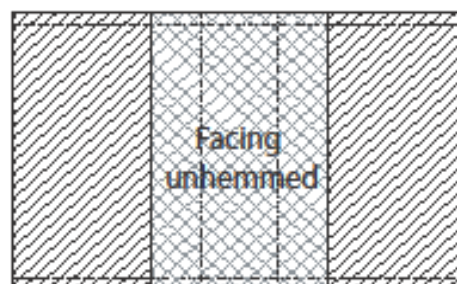

12. Stitch a 3/8" seam on top and bottom of unit. Turn right side out and press. Now your book cover is complete.

Insert book in cover by carefully folding back the front and back covers. Holding the center of the book, slowly slide the fabric cover into the front and back flap simultaneously easing the fabric into both covers. Poster board can be added inside the covers for reinforcement. Enjoy your new book cover!

